

charnwood  
**COVE**  
1 • 2 • 3

*Operating & Installation Instructions*

MK2



# COVE

## 1 • 2 • 3

### CONTENTS

#### OPERATING INSTRUCTIONS

Fuel	4
Door Operation	4
Multi Grate	4
Lighting	4
Controlling The Fire	5
Riddling	5
Refuelling	5
Ash Clearance	5
Maintenance	6
Throat Plate & Flueway Clearing	6
Chimney Sweeping	7
Trouble Shooting	7
If You Need Further Help	8

#### INSTALLATION INSTRUCTIONS

Health & Safety Precautions	9
Specification	9
Chimney	9
Hearth & Fire Surround	9
Connection to Flues	10
Soot Doors	10
Unpacking The Stove	10
Fitting The Stove To Its Stand	10
Pre Lighting Check	11
Commissioning	11
Dimensions	12 - 14
Parts Lists	15 - 17
Certification	18

Before lighting the stove check with the installer that the work and checks described in the Installation Instructions have been carried out correctly and that the chimney has been swept, is sound and free from any obstructions. The stove is not suitable for use in a shared flue system.

Your Cove stove has been designed to work with the minimum effort. If any operation - such as riddling the grate or opening and closing the door - begins to require extra force then the cause must be investigated and corrected to prevent damage being caused to the stove.

Remember that the stove will be hot and is made from hard material. Ensure that you have good balance before operating the fire.

When using the stove in situations where children, aged and/or infirm persons are present a fireguard must be used to prevent accidental contact with the stove. The fireguard should be manufactured in accordance with BS 8423:2002.

This stove is capable of intermittent operation.

## FUEL

Only dry well seasoned wood should be burnt on this appliance as burning wet unseasoned wood will give rise to heavy tar deposits in the stove, on the glass and within the chimney. For the same reason hard woods (such as Ash, Beech and Oak) are better than soft woods (such as Pine and Spruce). Burning wet unseasoned wood will also result in considerably reduced outputs. The wood should be cut and split and then left to season in a well ventilated dry place for at least one year but preferably two years before use.

**PETROLEUM COKE IS NOT SUITABLE FOR USE ON THIS APPLIANCE. ITS USE WILL INVALIDATE THE GUARANTEE.**

This stove is not designed to burn household waste. For advice on other fuels, please contact Charnwood.

## DOOR OPERATION

The door handle has been carefully designed to be removed from the stove during normal operation and re-fitted prior to loading and de-ashing. However, if you need to open the door when the fire is running at maximum then the additional use of a cloth or glove may be required.

Take care not to touch the door as it will be hot when the fire is burning. Turn the door handle anti-clockwise to open, and clockwise to close.

## MULTI GRATE

Your Charnwood Cove is fitted with a multi grate to enable wood to be burned and ash to be cleared. The grate has two positions:

- 1) In the open position the grate bars are vertical with gaps in between allowing the primary combustion air to come up through the grate and through the fuel bed.
- 2) In the closed position the grate bars are horizontal, allowing the combustion air to come round the sides of the grate and over the top of it. When in the closed position ash is able to build up on the grate as is necessary for effective wood burning.

Movement of the grate from one position to the other is effected using the door opening tool supplied as shown in Fig. 2. The grate is put into the open position by moving the tool up until the handle is in the 1 o'clock position. The grate is put into the closed position by moving the tool down. To riddle the appliance the tool should be moved between the lower and horizontal positions several times. When burning wood the ash should be allowed to build up and riddling should only be carried out once or twice a week.

Fig. 1. Stove Controls

Cove 1

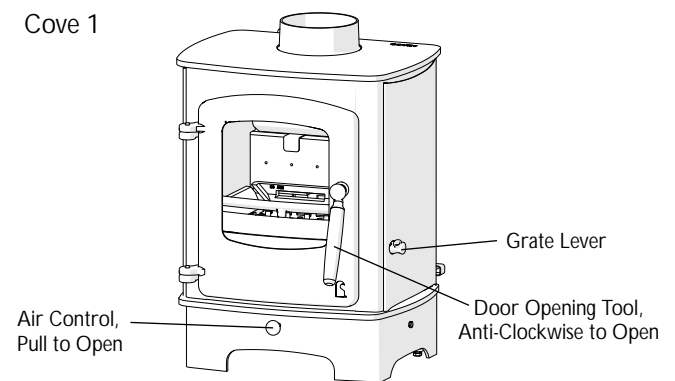

Cove 2 and 3

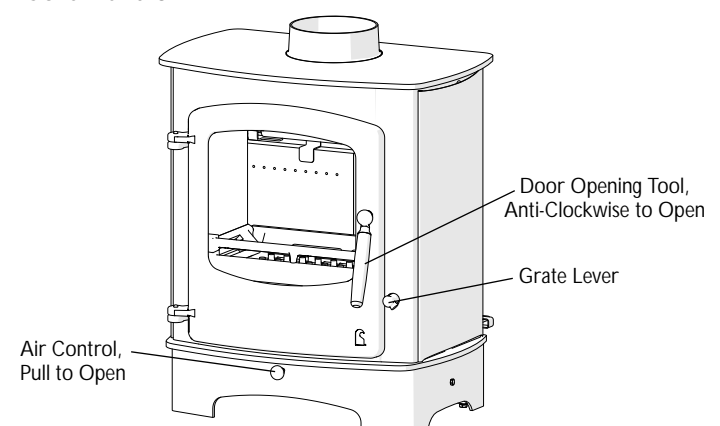

## LIGHTING

The stove may be lit using dry kindling wood and paper or fire lighters. Set the grate into either the closed position or the open position as required. Place the paper, or fire lighters, and kindling on the grate and cover with a few small dry logs. Open the air control fully (see Fig. 1). Light the paper or fire lighters. Close the door until the fuel is well ignited then load with fuel. Once the fire is up to temperature the airwash system will begin to work, so allow the fire to become hot before adjusting the air controls to the required setting.

On initial lighting, the stove may smoke and give off an odour as the silicon paint with which the firebox is painted reacts to the heat. This is normal and will cease after a short time, but meanwhile the room should be kept well ventilated.

At first only light a small fire and burn it slowly for two hours to allow any residual moisture in the bricks to evaporate.

When relighting the stove, riddle slightly, and then empty the ashpan.

## CONTROLLING THE FIRE

The fire is controlled by the single air control knob shown in Fig. 1. Pull the knob out to make the fire burn faster, push it in to make the fire burn slower.

This unique QuattroFlow™ air control\* provides carefully balanced primary, secondary, tertiary and bypass air to enable optimum burning conditions without the need to fiddle with multiple controls.

For correct firing we recommend the use of a stove pipe thermometer which may be purchased from your supplier or from ourselves.

## REFUELLING

Keep the firebox well filled but do not overfill to prevent fuel from spilling over the top of the front fire bar. Logs should be evenly distributed filling across the fire bed to give the most pleasing flame pattern.

Care should be taken especially when burning wood that fuel does not project over the front fire bar or damage to the glass may be caused when the door is closed, it can also cause the glass to blacken. Maximum filling height is such that logs cannot fall from the fire when the doors are opened. Liquid fuels are not to be used on this stove.

## RIDDLING

When burning wood, ash should be allowed to build up and only riddled when the ash begins to cover the slots in the rear fireplate. The fire should be riddled with the door shut (see Fig. 2). Place the tool onto the riddling lever and rotate between the lower and horizontal positions several times. Too much riddling can result in emptying unburnt fuel into the ashpan and should therefore be avoided. After riddling, the grate should be put back into the closed position for burning wood.

Fig. 2. Multi Grate

Cove 1

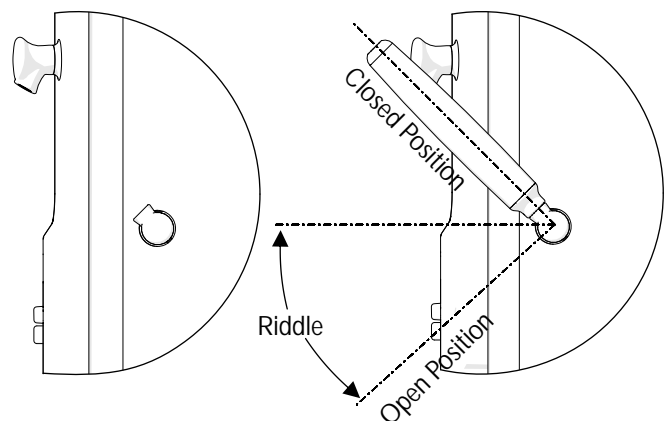

Cove 2 & 3

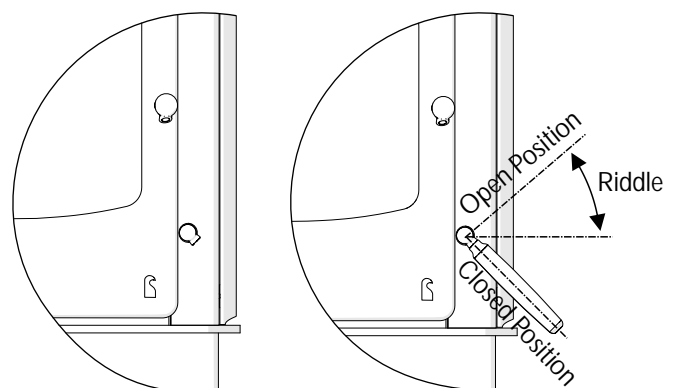

Door Opening Tool rotated 180° and pushed fully on to Riddler Knob

## ASH CLEARANCE

The ashpan should be emptied regularly before it becomes too full. Never allow the ash to accumulate in the ashpan so that it comes in contact with the underside of the grate as this will seriously damage the grate bars. The ashpan is handled using the Door Opening tool and gloves provided. Ensure that the tool is fully engaged before lifting (See Fig.3). When carrying the ashpan, it should be kept horizontal and supported by the carrying handle to prevent it falling off the tool. Care should be taken to ensure that ash is cool before emptying it into plastic liners or bins.

To make ash removal easier there is a special Charnwood ash carrier available. This may be purchased from your supplier or, in case of difficulty, from ourselves.

### Special Points when Burning Wood

The grate should be kept in the closed position and should not be riddled until the ash becomes so deep that it begins to block the passage of air into the firebox at the sides or back of the grate. When this is the case do not remove all of the ash using the riddling mechanism but keep a layer about half an inch thick as this enables the wood to burn more effectively. When lighting the fire a few small dry logs with a good amount of kindling will help to get the fire up to temperature quickly.

Fig. 3. Ashpan Removal

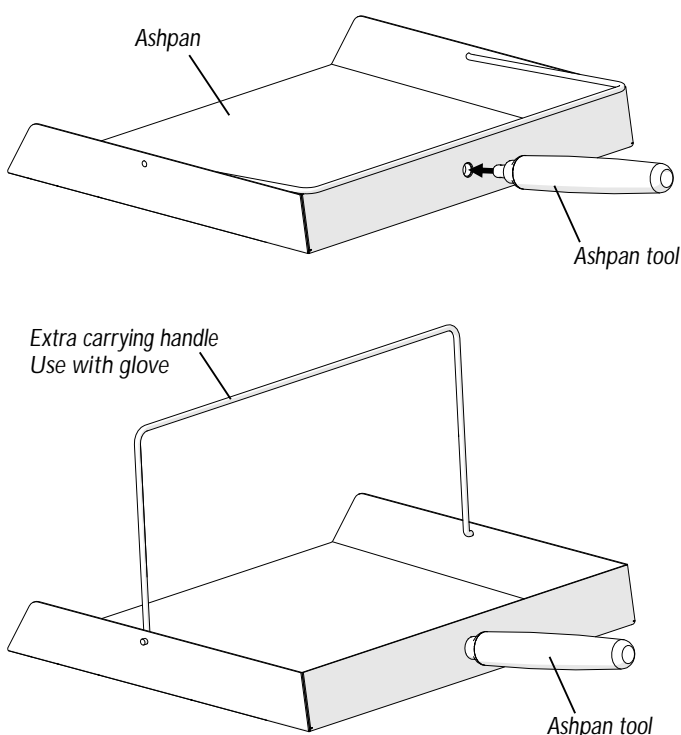

## MAINTENANCE

### Cleaning

The stove is finished with a high temperature paint which will withstand the temperatures encountered in normal use. This may be cleaned with a damp lint-free cloth or soft brush when the stove is cold. Should re-painting become necessary then special high temperature paints are available from your supplier or from Charnwood.

### Cleaning the Glass

The glass in the door is a special ceramic glass which is able to withstand high temperatures. Before cleaning the glass open the door and allow it to cool. Clean the glass using a damp cloth and then wipe over with a dry cloth. Any stubborn deposits on the glass may be removed with a proprietary stove glass cleaner or ceramic hob cleaner. Some deposits on the glass may be burnt off simply by running the fire at a fast rate for a few minutes. Do not use abrasive cleaners or pads as these can scratch the surface which will weaken the glass and cause premature failure. Aerosol spray cleaners should not be used near the appliance whilst it is under fire.

### When Not in Use

If the fire is going to be out of use for a long period (for instance in the summer) then to prevent condensation, and hence corrosion, the air control should be left fully open and the fire door left ajar. It is also advisable to sweep the chimney and clean out the fire. Spraying the inside of the door and firebox with a light oil, such as WD40, will also help to keep all internal parts working well.

After long periods where the fire has been out of use, the chimney and appliance flueways should be cleaned before lighting.

### Door Seals

For the fire to operate correctly it is important that the door seals are in good condition. Check that they do not become worn or frayed and replace them when necessary.

### Servicing

It is recommended that the fire is serviced once a year to keep it in first class working order. After cleaning out the firebox thoroughly, check that all internal parts are in good working order, replacing any parts that are beginning to show signs of wear. Check that the door seals are in good condition and that the door seals correctly. A servicing guide is available on request. Repairs or modifications may only be carried out by the Manufacturer or their approved agents. Use only genuine Charnwood replacement parts.

## THROAT PLATE AND FLUEWAY CLEANING

It is important that the throat plate and all the stove flueways are kept clean. They should be checked approximately once a week, by looking up into the firebox for signs of soot or fly-ash on the throat plate and at the sides of the firebox. If there are signs of a build up of soot or fly-ash deposits then the fire must be let out in order to clean the throat plate and flueways.

Before attempting to clean the throat plate and flueways ensure that the fire is cold. Wear suitable gloves to prevent irritation from soot deposits. To remove the throat plate lift the front edge up, pull the plate forwards to align the slots with the support pegs and then hinge the plate down from its back supports. Lift up from the back supports and rotate to remove through the doorway (see Fig. 4).

Fig. 4. Throat Plate

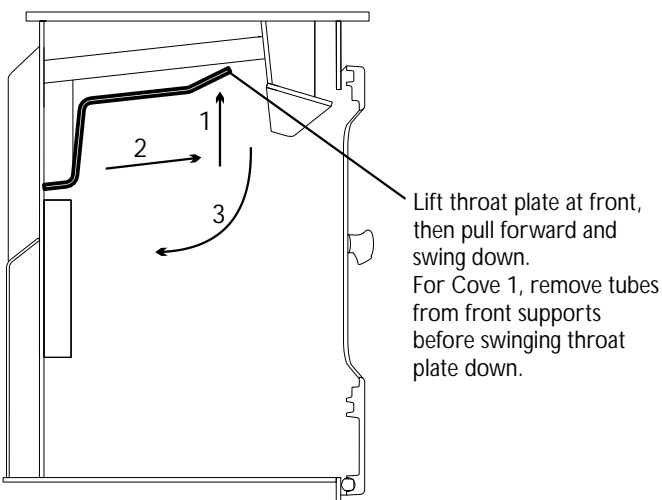

## CHIMNEY SWEEPING

The chimney should be swept at least once a year. Where a top outlet is used it will generally be possible to sweep the chimney through the appliance.

First remove the front firebar, side fire plates, and the throat plate. Then sweep the chimney ensuring that soot is removed from all horizontal surfaces after sweeping.

In situations where it is not possible to sweep through the appliance the installer will have provided alternative means, such as a soot door.

After sweeping the chimney the appliance flue outlet and the flue pipe connecting the stove to the chimney must be cleaned with a flue brush.

After clearing any soot from within the stove, replace the throat plate (see Fig. 4), the side fireplates, and front firebar.

Different types of sweep's brushes are available to suit different flueways. For standard brick chimneys a wire centre sweep's brush fitted with a guide wheel is recommended. For prefabricated insulated chimneys the manufacturers instructions with regard to sweeping should be consulted.

## TROUBLE SHOOTING

### Fire Will Not Burn

Check that:

- a) the air inlet at the rear of the stove is not obstructed in any way,
- b) chimneys and flueways are clear,
- c) a suitable fuel is being used,
- d) there is an adequate air supply into the room,
- e) an extractor fan is not fitted in the same room as the stove.
- f) there is sufficient draw in the chimney (once the chimney is warm a draught reading of at least 0.05 inches water gauge (12Pa) should be obtained).

### Blackening of Door Glass

Keeping the glass clean requires a certain amount of experimentation due to the differences in the draw of different chimneys. The following points should be noted and with a little care should enable the glass to be kept clean in most situations:

- a) The airwash relies on a supply of heated air to keep the glass clean, therefore, when lighting the stove allow the fire bed to become well established before closing the air control. This also applies when re-fuelling the stove.
- b) When re-fuelling keep the fuel as far back from the front firebar as possible, do not try to fit too much fuel into the firebox.
- c) Wet wood or logs overhanging the front firebars will cause the glass to blacken.
- d) There is a bypass slide that can be adjusted to suit the particular installation. This allows a small amount of airwash air to enter the stove even when the air control is closed. This can be adjusted to help with keeping the glass clean when the fire is slumbering.

It is always more difficult to keep the glass clean when running the stove very slowly for long periods.

Check that all flue connections and the blanking plate are well sealed. It is also important that the chimney draw is sufficient (when the chimney is warm a draught reading of at least 0.05 inches water gauge should be obtained), and that it is not affected by down-

draught.

## Fume Emission

Warning Note: Properly installed and operated this appliance will not emit fumes. Occasional fume from de-ashing and re-fuelling may occur. Persistent fume emission is potentially dangerous and must not be tolerated. If fume emission does persist, then the following immediate actions should be taken:

- a) Open doors and windows to ventilate the room.
- b) Let the fire out and safely dispose of the fuel from the appliance.
- c) Check for flue or chimney blockage, and clean if required.
- d) Do not attempt to re-light the fire until cause of fume has been identified. If necessary, seek professional advice.

The most common cause of fume emission is flueway or chimney blockage. For your own safety these must be kept clean.

## Fire blazing out of control

Check that :

- a) The door is tightly closed.
- b) The air control is pushed in.
- c) A suitable fuel is being used.
- d) Door seals and air control flap pads are intact.

## Chimney Fires

If the chimney is thoroughly and regularly swept, chimney fires should not occur. However, if a chimney fire does occur push the air control in fully and tightly close the door of the appliance. This should cause the chimney fire to go out in which case the control should be kept closed until the stove has gone out. The chimney and flueways should then be cleaned. If the chimney fire does not go out when the above action is taken then the fire brigade should be called immediately.

After a chimney fire the chimney should be carefully examined for any damage. Expert advice should be sought if necessary.

## IF YOU NEED FURTHER HELP

If you need further help with your Charnwood Cove then your Installer will be able to provide the answers to most questions. Your Local Charnwood Premier Dealer has a great deal of experience and will also be able to provide helpful advice. Further help is available from the Charnwood Customer Services department who will be pleased to give advice, if necessary.



## HEALTH & SAFETY PRECAUTIONS

Please take care when installing the stove that the requirements of the Health and Safety at Work Act 1974 are met.

Some types of fire cement are caustic and should not be allowed to come into contact with the skin. In case of contact wash with plenty of water.

If there is a possibility of disturbing any asbestos in the course of installation then please use appropriate protective equipment.

There must not be an extractor fan fitted in the same room as the stove as this can cause the appliance to emit fumes into the room.

There must be an adequate air supply into the room in which the appliance is installed to provide combustion air. The combustion air supply must be via a permanently open vent. There is no requirement for Cove 1, but minimum free areas are:

Cove 2	16.5cm <sup>2</sup> (2.5 in <sup>2</sup> )
Cove 3	38.5cm <sup>2</sup> (6 in <sup>2</sup> )

This is particularly necessary if the room is double glazed. It must be positioned such that it is not liable to blockage.

In addition to these instructions the requirements of BS.8303 and BS EN15287-1:2007 must be fulfilled. Local Authority Bylaws and Building Regulations regarding the installation of Solid Fuel burning appliances, flues and chimneys must also be observed, including those referring to national and European Standards.

## SPECIFICATION

	<i>Cove 1</i>	<i>Cove 2</i>	<i>Cove 3</i>
<b>Output kW</b>	<b>4.0</b>	<b>8.0</b>	<b>12.0</b>
<b>(BTU/h)</b>	<b>(13,700)</b>	<b>(27,300)</b>	<b>(41,000)</b>
<b>Mass (kg)</b>			
<i>Low Stand</i>	<b>89</b>	<b>127</b>	<b>159</b>
<i>Low Arch Stand</i>	<b>89</b>	<b>127</b>	<b>159</b>
<i>Midi Stand</i>	<b>92</b>	<b>130</b>	<b>168</b>
<i>Store Stand</i>	<b>96</b>	<b>133</b>	<b>171</b>
<i>Centre Stand</i>	<b>104</b>	<b>146</b>	<b>187</b>
<b>Flue Gas Temp °C</b>	<b>275</b>	<b>300</b>	<b>320</b>
<b>Flue Gas Mass Flow G/S</b>	<b>3.6</b>	<b>6.5</b>	<b>12</b>
<b>Max Hearth Temp °C</b>	<b>39</b>	<b>25</b>	<b>36</b>

*The outputs were obtained burning seasoned hardwood over a 1.5 hourly re-fuelling cycle.*

## CHIMNEY

In order for the appliance to perform satisfactorily the chimney height must not be less than 4 metres measured vertically from the outlet of the stove to the top of the chimney. The minimum internal chimney sizes are as follows:

COVE 1 ..... 150mm diameter(6 inches) or 150mm x 150mm  
 COVE 2 ..... 150mm diameter(6 inches) or 150mm x 150mm  
 COVE 3..... 180mm diameter (7 inches) or 180mm x 180mm  
 These stoves are NOT to be used in a shared flue. If an existing chimney is to be used it must be swept and checked, it must be in good condition, free from cracks and blockages, and should not have an excessive cross sectional area. If you find that the chimney is in poor condition then expert advice should be sought regarding the necessity of having the chimney lined. If it is found necessary to line the chimney then a lining suitable for Solid Fuel must be used.

If there is no existing chimney then a prefabricated block chimney or a twin walled insulated stainless steel flue to BS EN15287-1:2007 can be used either internally or externally. These chimneys must be fitted in accordance with the manufacturers instructions and Building Regulations.

Anki pumice liners or chimney blocks will give a highly insulated chimney which will work well with all fuels. For details ring Anki Chimney Systems on (01983) 527997.

Single wall flue pipe is suitable for connecting the stove to the chimney but is not suitable for using for the complete chimney.

If it is found that there is excessive draw in the chimney then a draught stabilizer should be fitted.

It is important that there is sufficient draw in the chimney and that the chimney does not suffer from down-draught. When the chimney is warm the draw should be not less than 0.05 inches water gauge (12pa). If in doubt about the chimney seek expert advice.

## HEARTH AND FIRE SURROUND

The stove must stand on a fireproof hearth and must be situated at least the following distances from any combustible material:

	COVE 1	COVE 2	COVE 3
Side	550mm (22in)	450mm (18in)	500mm(20in)
Back	550mm (22in)	600mm (24in)	500mm (20in)

The hearth must be at least 12mm (0.5inches) thick. The positioning of the stove and the size of the hearth are governed by building regulations for Class 1 appliances. These building regulations state that the hearth must extend in front of the stove by at least 225mm (9 inches) and to the sides of the stove by at least 150mm (6 inches). When the fire door is open, it extends beyond the front of the stove by:

COVE 1	COVE 2	COVE 3
390mm (15.3in)	414mm (16.3in)	491mm (19.3in)

If in doubt as to the positioning of the stove expert advice should be sought either from the supplier or the local building inspector.

The fireplace must allow good circulation of air around the appliance to ensure that maximum heat is transferred to the room and also to prevent the fireplace from overheating. A gap of 150mm (6 inches) each side and 300mm (12 inches) above the appliance should give sufficient air circulation. If a wooden mantelpiece or beam is used in the fireplace it should be a minimum of 460mm (18 inches), and preferably 600mm (24 inches) from the appliance. In some situations it may be necessary to shield the beam or mantelpiece to protect it.

In order for the fire to operate correctly there must be an air gap behind the appliance of at least 40mm, but be aware that this distance will need to be greater in some cases to meet Building Regulation requirements.

## CONNECTIONS TO FLUES

There are several ways of connecting the stove to the flue. These are illustrated in figures 6 to 9.

If the vertical rear flue connector (shown in Fig. 9) is used then the chimney may be swept through the appliance.

Horizontal lengths of flue must be kept to a minimum and should not be more than 150mm (6 inches) long. The sealing face of the flue collar should be coated with fire cement before fixing to the body of the stove using the two screws provided. The blanking plate must be removed, sealed with fire cement and refitted, care being taken to ensure that the fold on the clamping plate is in line with the lugs on the firebox as shown on the label on the clamping plate. Ensure that the clamping plate does not prevent the throat plate from seating correctly. All flue connections must be well sealed.

## SOOT DOORS

It is possible to pass a 16" diameter sweep's brush through the appliance but in most back outlet installations it will be necessary to have a soot door to enable the chimney to be swept. This may either be in the actual brickwork of the chimney or in the register plate. Various types and positions of soot doors are shown in figs. 6 to 9.

## UNPACKING THE STOVE

The stove arrives bolted its pallet with 2 banding straps and covered with a box. The packaging is first carefully removed, then the stove released from the pallet by removing the 4 brackets using a 13mm spanner.

The pallet is intended to be cut up and used for kindling fuel.

Ensure that the levelling bolts attached to the stand support brackets come below the low stand and low arch stand so that the stand can be removed when servicing the air box.

## FITTING THE STOVE TO ITS STAND

### 1. Centre stand

The Stand is first positioned on the hearth in the desired position of the stove. Ensure that the pallet brackets and 2 button head screws have been removed from the stove, then lift the stove on to the stand, aligning the 4 tapped holes in the base brackets with the 4 slots in the top of the stand. NOTE: This requires at least 2 people.

Fig. 5

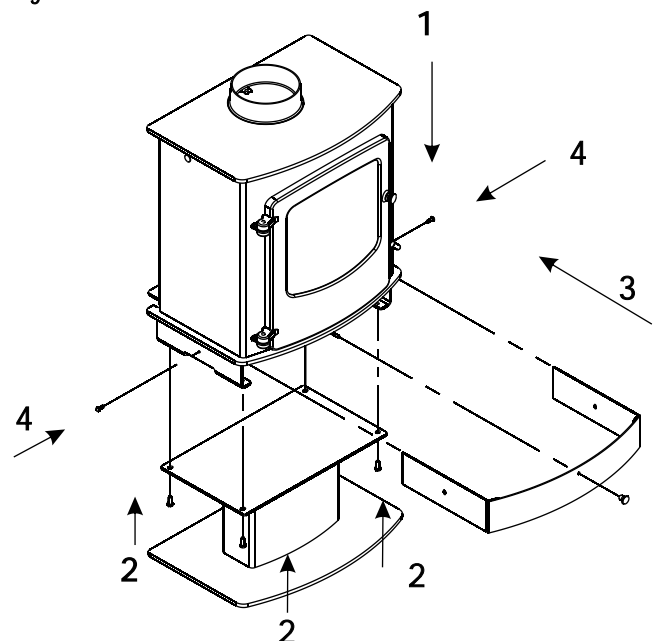

The stove is fixed to its stand using 4 M8 x 20mm bolts and 4 plain washers. A 13mm open ended spanner is required. Fit the cover, side bolts and Air Control Knob.

### 2. Store stand and Midi stand

Place the Stand on the hearth, with at least 100mm clear space behind it. Remove the button head hex screws from the side brackets. With 2 people, carefully lift the stove on to the stand such that the front end of the Air Control Rod is lowered down inside the stand. Take care not to bend or damage the Air Control Rod. Temporarily rest the stove on the stand in this position and pull the Air Control Rod through the hole in the front of the stand. Now move the stove towards you to align the slots in the side of the stand

with the 6mm tapped holes in the base brackets. Fix in position with button head hex screws and replace the Air Control Knob.

## PRE LIGHTING CHECK

Before initial lighting the following points should be checked:

1. The bottom grate bars must all be fitted and should move freely and easily when the riddling mechanism is operated.
2. The plates round the sides and back of the grate must be in position and sitting correctly.
3. The throat plate must be fitted in the roof of the appliance and should be checked to ensure that it has not become dislodged in

Fig. 6. Vertical register plate with bricked up fireplace

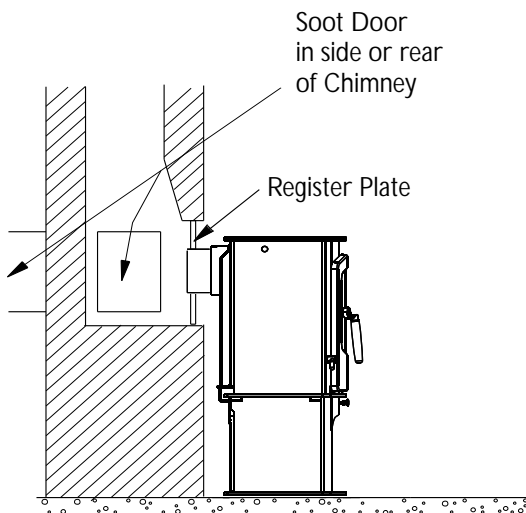
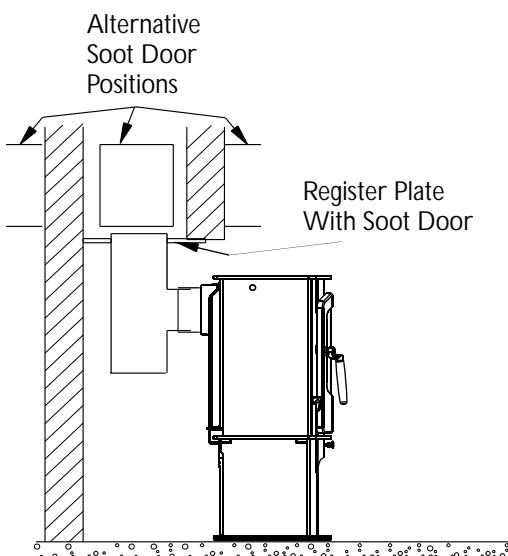

Fig. 7. Horizontal register plate with rear flue connection



transit. The method of location and positioning of the throat plate is shown in Fig. 4.

## COMMISSIONING

On completion of the installation and after allowing a suitable period of time for the fire cement and mortar to dry out, the stove should be lit and checked to ensure that smoke and fumes are taken from the appliance up the chimney and emitted safely. Also check all joints and seals. On completion of the installation and commissioning please leave the operating instructions with the customer and advise them on the use of the appliance.

Fig. 8. Horizontal register plate with top flue connection

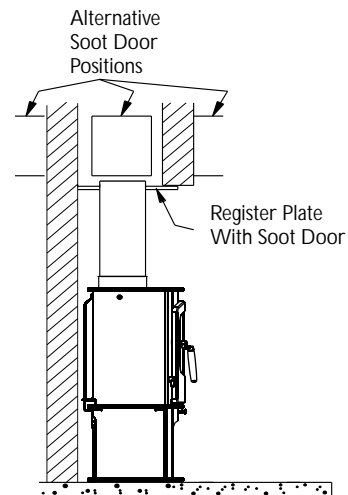
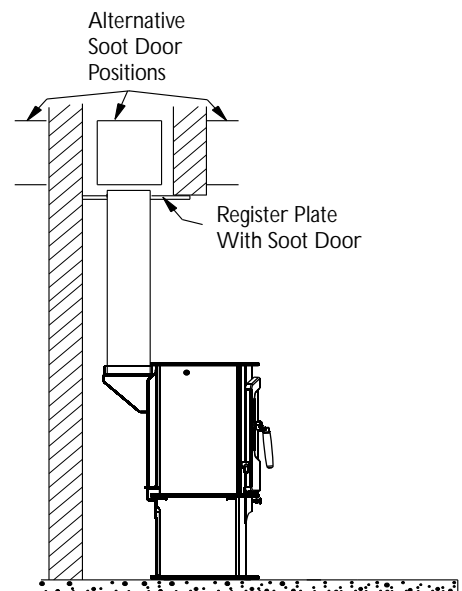
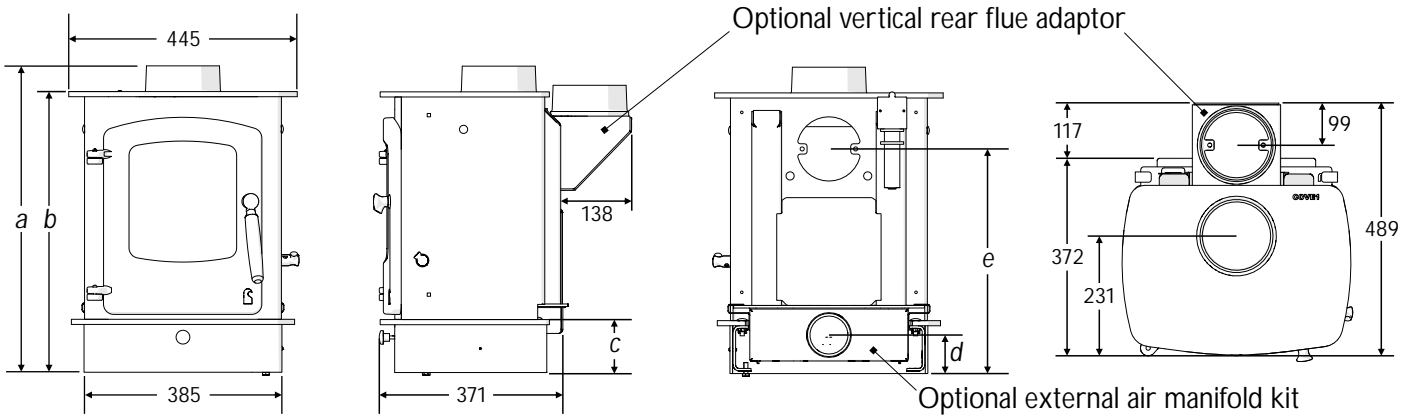

Fig. 9. Horizontal register plate with optional vertical rear flue connector



# COVE 1 MKII DIMENSIONS (mm)



FRONT VIEW

SIDE VIEW

BACK VIEW

TOP VIEW

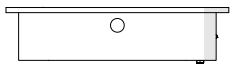
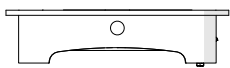
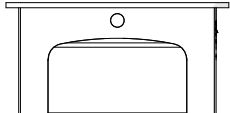
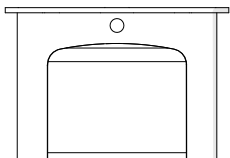
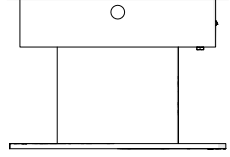
		<i>a</i>	<i>b</i>	<i>c</i>	<i>d</i>	<i>e</i>
LOW STAND (Shown above)		596	546	103	75	437
LOW ARCH STAND		596	546	103	75	437
MIDI STAND		723	673	230	202	564
STORE STAND		795	745	302	274	636
CENTRE STAND		795	745	302	274	636

# COVE 2 MKII DIMENSIONS (mm)

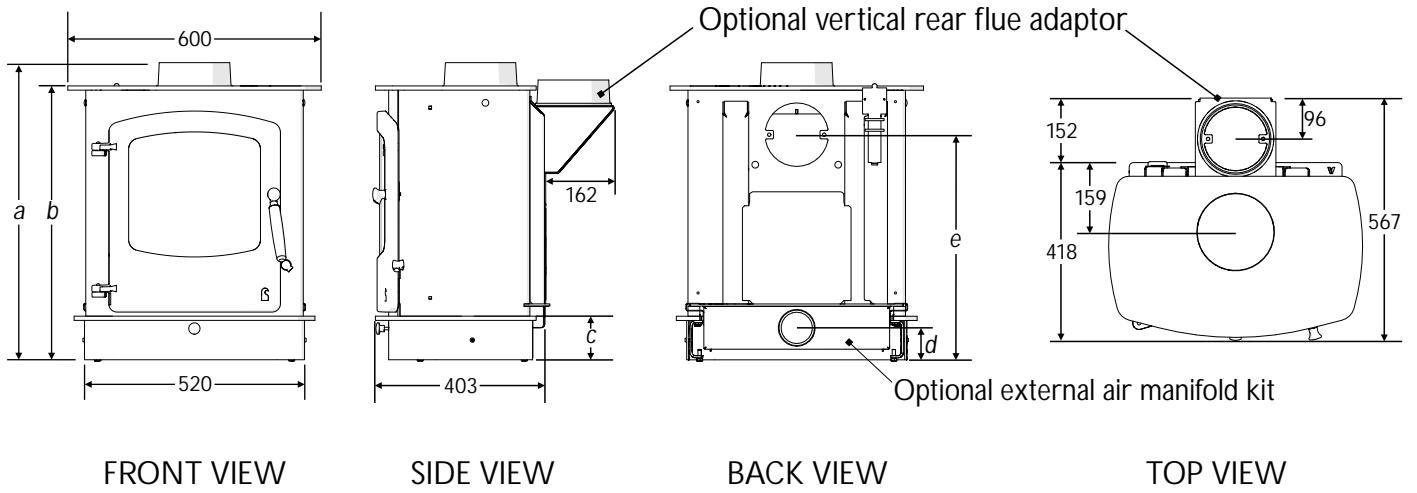

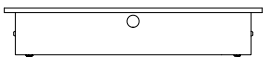
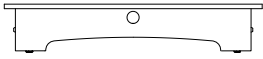
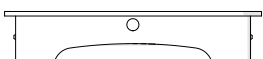
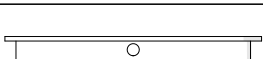
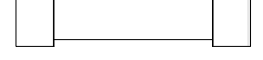
		<i>a</i>	<i>b</i>	<i>c</i>	<i>d</i>	<i>e</i>
LOW STAND (Shown above)		697	647	103	76	532
LOW ARCH STAND		697	647	103	76	532
MIDI STAND		824	774	230	203	659
STORE STAND		944	894	350	323	779
CENTRE STAND		944	894	350	323	779

# COVE 3 MKII DIMENSIONS (mm)

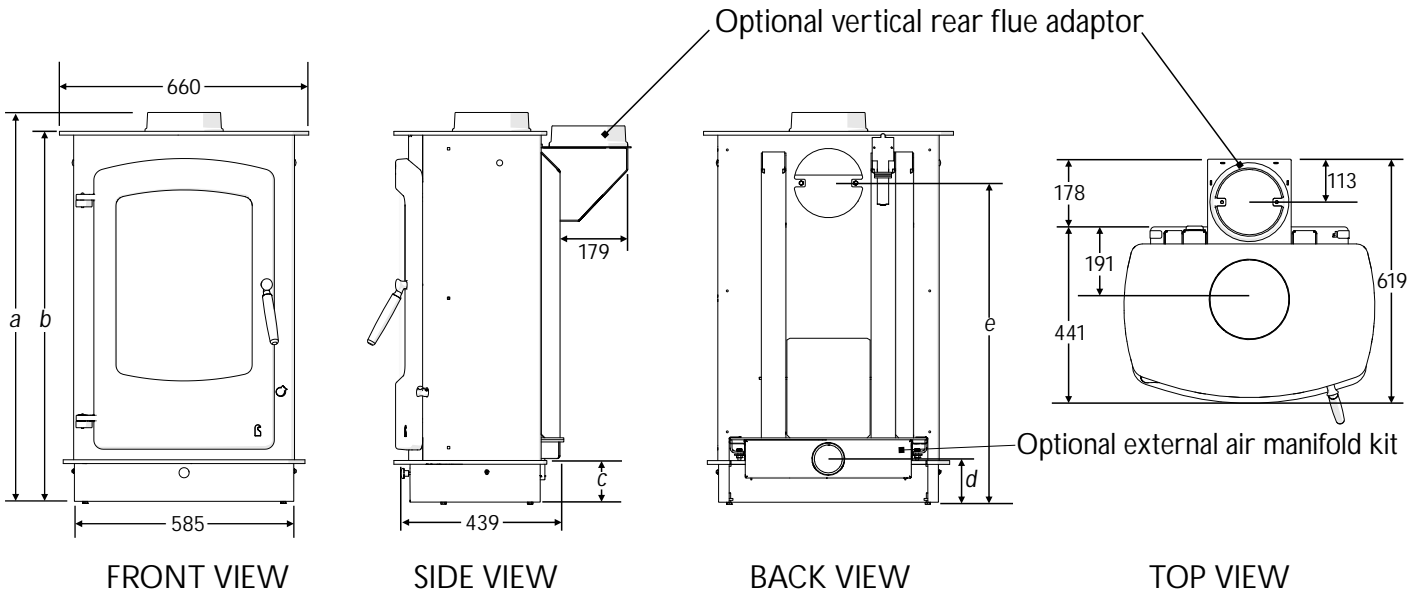

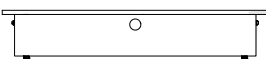
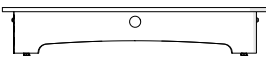
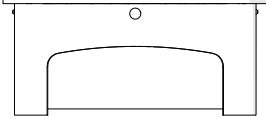
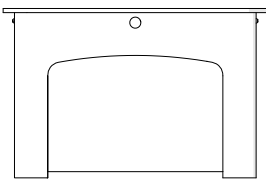
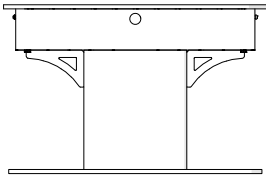
		<i>a</i>	<i>b</i>	<i>c</i>	<i>d</i>	<i>e</i>
LOW STAND <i>(Shown above)</i>		1130	980	110	115	844
LOW ARCH STAND		1130	980	110	115	844
MIDI STAND		1200	1150	280	285	1014
STORE STAND		1330	1280	410	415	1144
CENTRE STAND		1330	1280	410	415	1144

# CHARNWOOD COVE 1 MkII PARTS LIST

Issue A

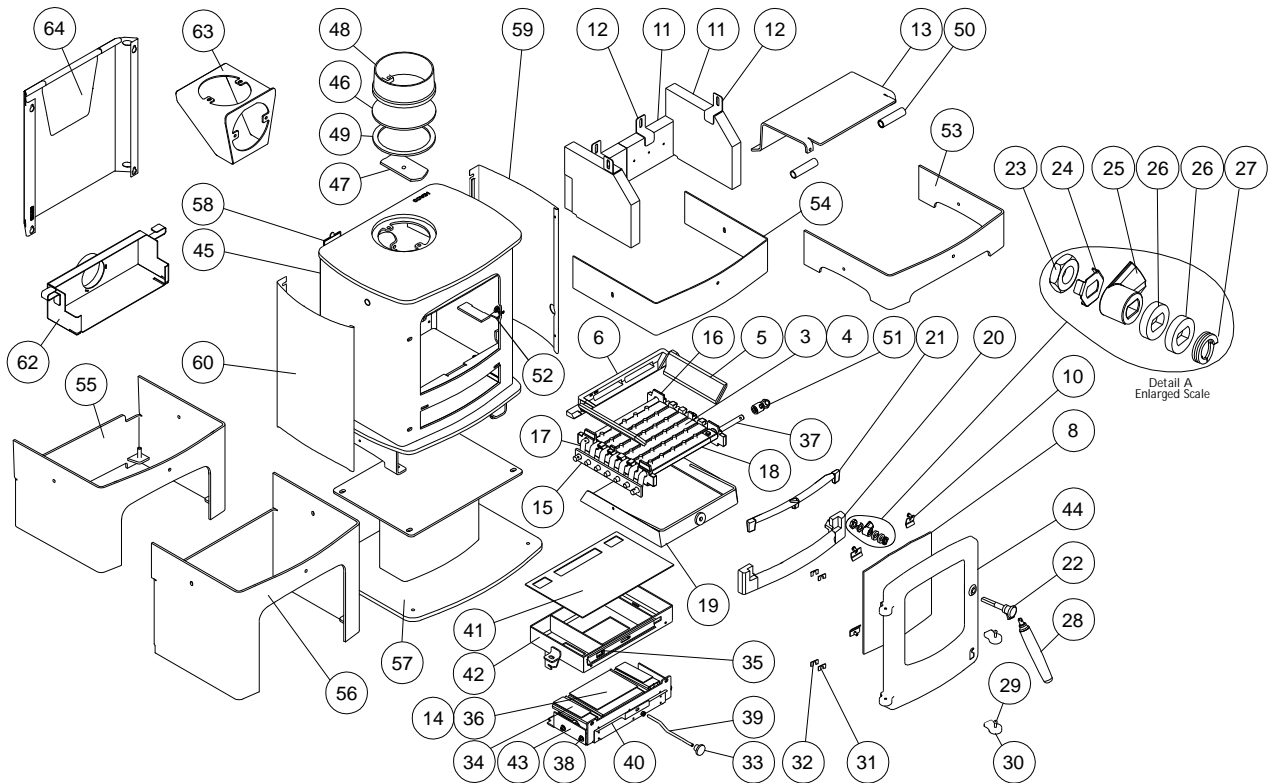

Item	Part No.	Description	Item	Part No.	Description
1*	008/SY16S	Door Seal Set Inc. Adhesive	34	004/AY22-1S	Secondary/Bypass Air Inlet Flap
2*	008/FW29	Door Seal Adhesive	35	004/SY21	Air Bypass Slide
3	002/CG01	Bottom Grate Bar	36	004/CY22P	Primary Air Inlet Flap
4	002/CG01S5	Set of Grate Bars(5)	37	002/CG11	Driving Rod
5	002/SY15	Side Fire Plate	38	004/SY24	Flap Mounting Rod (Inc. Fixings)
6	002/HW16	Back Fire Plate	39	004/SY27	Air Control Rod
8	006/SY18	Glass (Inc Seal)	40	004/SY23	Actuator Assembly
9*	008/SY43	Glass Seal	41	008/SY13	Upper Quattro Box Gasket
10	004/KV23	Glass Retainer	42	010/SY20	Upper Quattro Box
11	011/SY29S	Set of Fire Bricks (4)	43	010/SY19	Lower Quattro Box
12	004/XV30	Brick Retainer	44#	002/SX01/A	Door Assembly
13	010/SY31	Throat Plate	45	001/SX10	Firebox (Cove1 MkII)
14	008/SY26S	Set of Air Inlet Flap Pads	46	012/PV09	Blanking Plate
15	012/SY33	Mover Bar	47	010/EY51	Clamping Plate
16	002/SY30	Carrier Bar	48	002/PV12B	Flue Collar
17	012/CG05	Idler Rod	49	010/EY19	Flue Spacer Ring
18	002/CG12	Driving Gratebar	50	010/SY06	Throatplate Support Tube
19	004/SX17	Ashpan	51	002/PX89	Riddler Knob
20	002/SY07	Front Firebar	52	010/PY38	Door Catch Stop
21	002/SY08	Deepening Bar	53#	010/SX32	Low Arch Stand
22	002/PX92	Door Knob & Spindle	54#	010/SY11	Low Stand
23	008/FFN001	M12 Half Nut	55#	010/SX35	Mid Stand
24	004/ST008	Tabbed Locking Washer	56#	010/SY02	Store Stand
25	002/AY14	Door Catch	57#	010/SY12	Centre Stand
26	010/ST031	Door Catch Spacer	58	012/SY25	Serial No. Label
27	008/FFW015	M12 Double Coil Spring Washer	59#	005/SX93R	RH Curved Side Panel
28	008/PX95	Door/Riddling/Ashpan Tool	60#	005/SX93L	LH Curved Side Panel
29	008/BW39/S	Hinge Pin Set	61*	010/EW51	Ash Carrier (Optional Extra)
30	002/PY24	Hinge Post	62	010/SY52A	External Air Manifold Kit
31	004/PY25B	Hinge Post Shim 0.9mm	63#	010/PV33	Vert. Rear Flue Adapter (Opt'l Extra)
32	004/PY25A	Hinge Post Shim 2mm	64#	010/SX80	Heatshield
33	008/AY37	Air Control Knob			

\* These items are not shown on the drawing.

# Please specify colour when ordering.

To obtain spare parts please contact your local stockist giving Model, Part No. and Description. In case of difficulty contact the manufacturer at the address shown.

This drawing is for identification purposes only.

# CHARNWOOD COVE 2 MKII PARTS LIST

Issue A

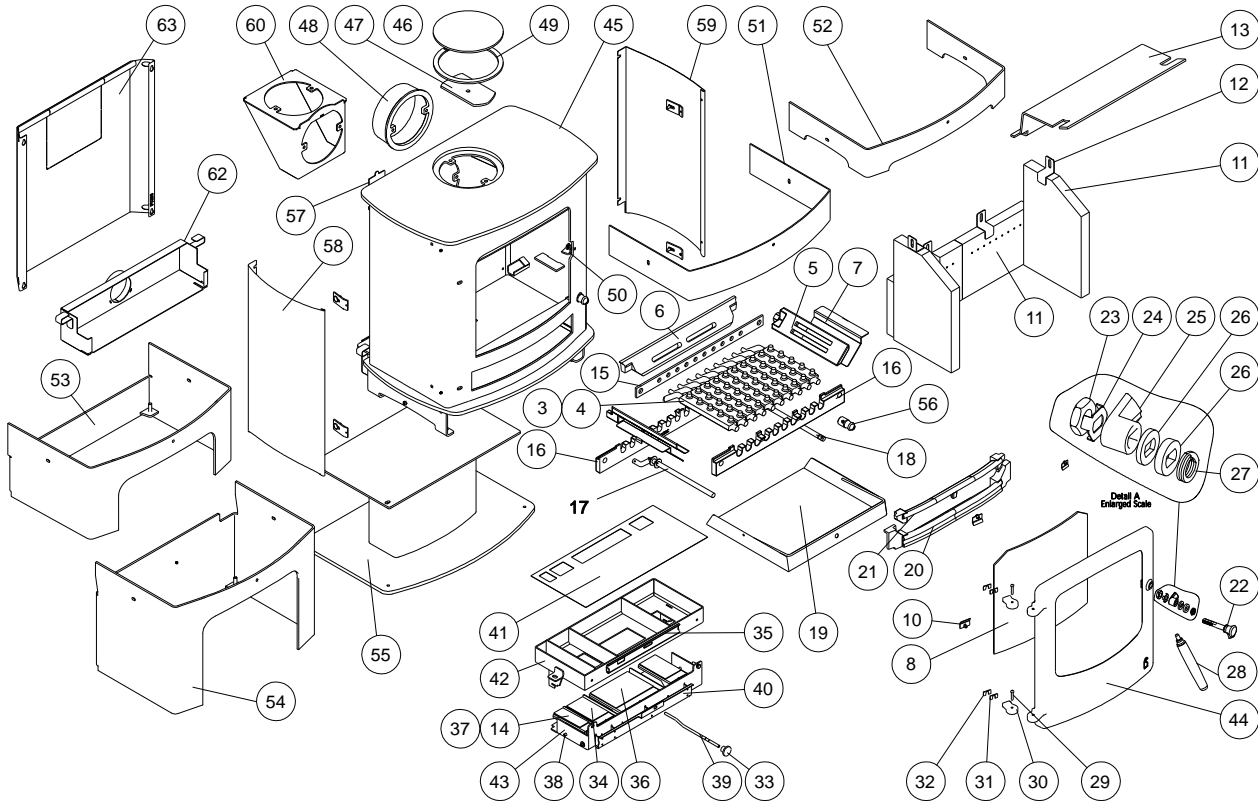

Item	Part No.	Description	Item	Part No.	Description
1*	008/PY23S	Door Seal Set Inc. Adhesive	33	008/AY37	Air Control Knob
2*	008/FW29	Door Seal Adhesive	34	004/CY22S	Secondary Air Inlet Flap
3	002/CG20	Bottom Grate Bar	35	004/CY21	Air Bypass Slide
4	002/CG20S10	Set of Grate Bars (10)	36	004/CY22P	Primary Air Inlet Flap
5	002/CY15	Side Fire Plate	37	004/AY22-1S	Secondary/Bypass Air Inlet Flap
6	002/AY16	Back Fire Plate	38	004/CY24	Flap Mounting Rod (Inc. Fixings)
7	004/BY24	Ash Shedding Plate	39	004/PY32	Air Control Rod
8	006/PY18	Glass (Inc Seal)	40	004/CY23	Actuator Assembly
9*	008/PY45	Glass Seal	41	008/RV16	Upper Quattro Box Gasket
10	004/KV23	Glass Retainer	42	010/PY20	Upper Quattro Box
11	011/PY29S	Set of Fire Bricks (4)	43	010/CY19	Lower Quattro Box
12	004/XV30	Brick Retainer	44#	002/PX01/A	Door Assembly
13	010/PY31	Throat Plate	45	001/PX10	Firebox (Cove 2 MkII)
14	008/CY26S	Set of Air Inlet Flap Pads	46#	012/TW09	Blanking Plate
15	012/AY33	Mover Bar	47	010/AY51	Clamping Plate
16	002/AY30	Carrier Bar	48#	002/CH12B	Flue Collar
17	012/AY13	Idler Rod	49	010/NV11	Flue Spacer Ring
18	012/AY15	Riddler Rod	50	010/PY38	Door Catch Stop
19	004/PX17	Ashpan	51#	010/PY36	Low Stand
20	002/AY07B	Front Firebar	52#	010/PX32	Low Arch Stand
21	002/AY08	Deepening Bar	53#	010/PX35	Midi Stand
22	002/PX92	Door Knob & Spindle	54#	010/PY33	Store Stand
23	008/FFN001	M12 Half Nut	55#	010/PY34	Centre Stand
24	004/ST008	Tabbed Locking Washer	56	002/PX89	Riddler Knob
25	002/AY14	Door Catch	57	012/PX19	Serial No. Label
26	010/ST031	Door Catch Spacer	58#	005/PX93L	LH Curved Side Panel
27	008/FFW015	M12 Double Coil Spring Washer	59#	005/PX93R	RH Curved Side Panel
28	008/PX95	Door/Riddling/Ashpan Tool	60#	010/TW33	Vert. Rear Flue Connector (Opt'l Extra)
29	008/BW39/S	Hinge Pin Set	61*	010/BW51	Ash Carrier (Optional Extra)
30	002/PY24	Hinge Post	62	010/PY52A	External Air Manifold Kit (Optional Extra)
31	004/PY25B	Hinge Post Shim 0.9mm	63#	010/PX80	Heat shield (Optional Extra)
32	004/PY25A	Hinge Post Shim 2mm			

\* These items are not shown on the drawing.

# Please specify colour when ordering.

To obtain spare parts please contact your local stockist giving Model, Part No. and Description. In case of difficulty contact the manufacturer at the address shown.

This drawing is for identification purposes only.



# CHARNWOOD COVE 3 MkII PARTS LIST

Issue C

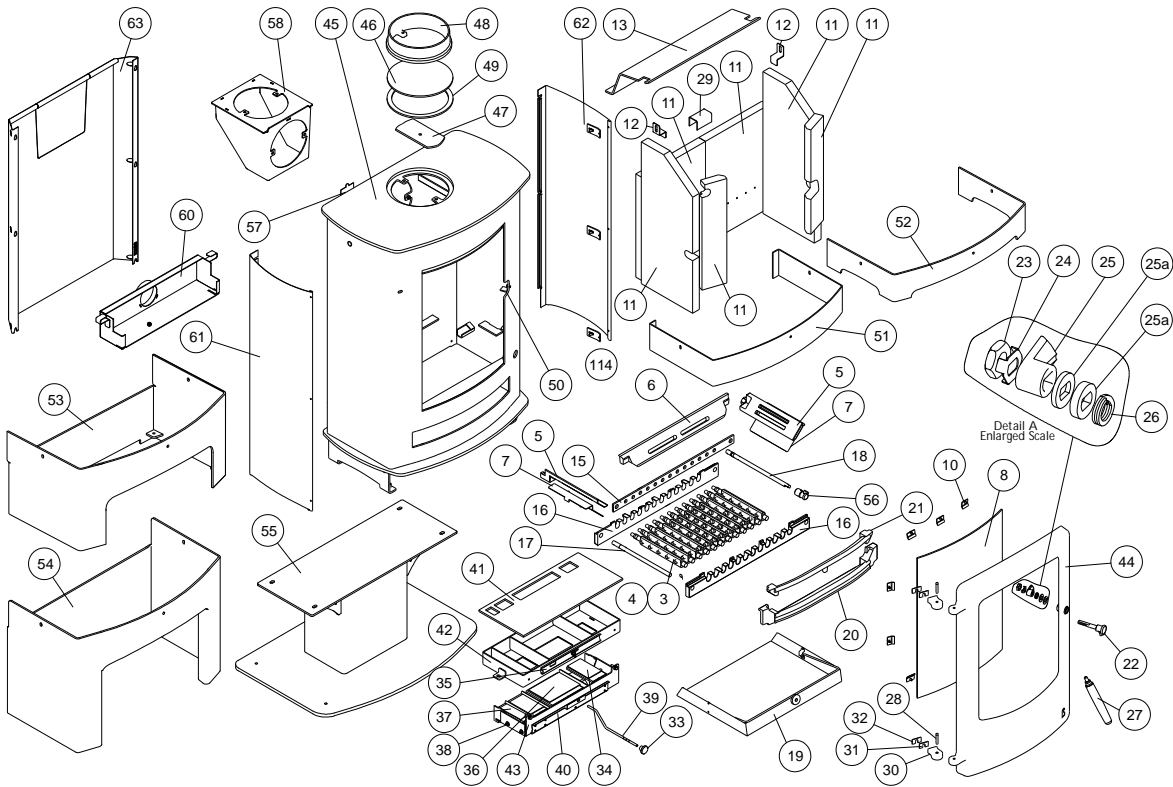

Item	Part No.	Description	Item	Part No.	Description
1*	008/RV23S	Door Seal Set Inc. Adhesive	32	004/RV25A	Hinge Post Shim 2mm
2*	008/FW29	Door Seal Adhesive	33	008/AY37	Air Control Knob
3	002/CG20	Bottom Grate Bar	34	004/CY22S	Secondary Air Inlet Flap
4	002/CG20S12	Set of Grate Bars (12)	35	004/CY21	Air Bypass Slide
5	002/CY15	Side Fire Plate	36	004/CY22P	Primary Air Inlet Flap
6	002/BY16	Back Fire Plate	37	004/AY22-1S	Secondary/Bypass Air Inlet Flap
7	004/BY24	Ash Shedding Plate	38	004/CY24	Flap Mounting Rod (Inc. Fixings)
8	006/RV18	Glass (Inc Seal)	39	004/RV32	Air Control Rod
9*	008/RV45	Glass Seal	40	004/CY23	Actuator Assembly
10	004/KV23	Glass Retainer	41	008/RV16	Upper Quattro Box Gasket
11	011/RX27S	Set of Fire Bricks (6)	42	010/PY20	Upper Quattro Box
12	004/XV30	Brick Retainer	43	010/CY19	Lower Quattro Box
13	010/RV31	Throat Plate	44#	002/RX01/A	Door Assembly
14	008/CY26S	Set of Air Inlet Flap Pads	45	001/RX10	Firebox (Cove 3 MkII)
15	012/BY33	Mover Bar	46	010/CY37	Blanking Plate
16	002/BY30	Carrier Bar	47	010/CY61	Clamping Plate
17	012/AY13	Idler Rod	48#	010/CY45	Flue Collar
18	012/AY15	Riddler Rod	49	010/CY36	Flue Spacer Ring
19	004/RX17	Ashpan	50#	010/RV08	Door Stop
20	002/BY07B	Front Firebar	51#	010/RV13	Low Stand
21	002/BY08	Deepening Bar	52#	010/RX32	Low Arch Stand
22	002/PX92	Door Knob & Spindle	53#	010/RX35	Midi Stand
23	008/FFN001	M12 Half Nut	54#	010/RV11	Store Stand
24	004/ST008	Tabbed Locking Washer	55#	010/RX12	Centre Stand
25	002/AY14	Door Catch Cam	56	002/PX89	Riddler Knob
25a	010/ST031	Door Catch Spacer	57	012/RV19	Serial No. Label
26	008/FFW015	M12 Double Coil Spring Washer	58	010/CY34	Vert. Rear Flue Connector (Opt'l Extra)
27	008/PX95	Door/Riddling/Ashpan Tool	59*	010/BW51	Ash Carrier (Opt' l Extra)
28	008/PV28/S	Hinge Pin Set (2 Per Set)	60	010/PY52A	External Air Manifold Kit (Opt' l Extra)
29	004/GV24	Rear Brick Joining Bracket	61#	005/RX93L	LH Curved Side Panel (Opt' l Extra)
30	002/RV26	Hinge Post	62#	005/RX93R	RH Curved Side Panel (Opt' l Extra)
31	004/RV25B	Hinge Post Shim 0.9mm	63#	010/RX80	Heatshield (Opt' l Extra)

\* These items are not shown on the drawing.  
# Please specify colour when ordering.

To obtain spare parts please contact your local stockist giving Model, Part No. and Description. In case of difficulty Contact the manufacturer at the address shown.  
This drawing is for identification purposes only.

# charnwood



A.J WELLS & SONS LTD

10

*Bishops Way, Newport, Isle of Wight PO30 5WS, United Kingdom*

A Division of A.J.Wells & Sons Limited Registered in England No. 03809371

EN13240:2001

## COVE

1 • 2 • 3

ROOMHEATERS FIRED BY SOLID FUEL

	Cove 1	Cove 2	Cove 3
EC certificate of conformity no:	SY44-CPD-2006	PY44-CPD-2006	RY44-CPD-2006
Minimum distance to combustible materials:			
Side:	550mm	450mm	500mm
Rear:	550mm	600mm	500mm
Emission of CO in combustion products:	0.47%	0.33%	0.23%
Flue gas temperature:	275°C	338°C	310°C
Space heating thermal output:	4.1kW	8.0kW	12.0kW
Energy efficiency:	76.5%	74.7%	78.4%
Fuel types:	Wood Logs	Wood Logs	Wood Logs

*your premier dealer*

REV.COV.12.3.1M62.1014

**charnwood** BISHOPS WAY, NEWPORT, ISLE OF WIGHT PO30 5WS, UNITED KINGDOM  
T:+44 (0)1983 537777 • F:+44 (0)1983 537788 • CONTACT US AT [WWW.CHARNWOOD.COM](http://WWW.CHARNWOOD.COM)

